

Universal and non-universal features in a model of city traffic

B. A. Toledo,¹ E. Cerda,¹ J. Rogan,² V. Muñoz,²

C. Tenreiro,³ R. Zarama,⁴ and J. A. Valdivia^{2,5}

¹*Departamento de Física, Universidad de Santiago de Chile, Chile*

²*Departamento de Física, Facultad de Ciencias, Universidad de Chile*

³*Departamento de Ingeniería, Universidad de Talca, Chile*

⁴*Departamento de Ingeniería Industrial, Universidad de los Andes, Colombia*

⁵*Departamento de Física, Universidad de los Andes, Colombia*

The complex behavior that occurs when traffic lights are synchronized is studied. Two strategies are considered: all lights in phase, and a “green wave” with a propagating green signal. It is found that traffic variables such as traveling time, velocity and fuel consumption, near resonance, follow critical scaling laws. For the green wave, it is shown that time and velocity scaling laws hold even for random separation between traffic lights. These results suggest the concept of transient resonances, which can be induced by adaptively changing the phase of traffic lights. This may be important to consider when designing strategies for traffic control in cities, where short trajectories, and thus transient solutions, are likely to be relevant.

I. INTRODUCTION

Urban traffic is not only interesting because of its obvious social and economic impact, but also because of its complex behavior [1, 2] which is observed daily by drivers. For instance, differences in the timing of traffic lights can affect traffic over long distances, or the presence of a few extra cars can suddenly lead to huge extra delays, etc. From a scientific viewpoint, this behavior is so rich that it can be studied from several perspectives, ranging from statistical and cellular automaton models to hydrodynamical and mean field approaches [1, 3–10]. Of particular interest is the emergence of traffic jams as a collective phenomenon ([11–13] among others).

On the other hand, it is worth noticing that the timing of traffic lights must be close to the characteristic traveling time (e.g., including car interaction and so on) between signals,

since longer or shorter timing will slow down the car mean speed, and may contribute to jam the road [13]. This suggests that resonant conditions may lead to efficient traffic systems. Moreover, it will be shown that around resonance, for the model presented in this paper, dynamical variables follow certain power laws. Such power laws resemble scaling relations near second order phase transitions, and in view of this analogy we refer to them as critical behavior. We plan to characterize this criticality and derive the critical behavior close to the resonance in terms of traveling time, velocity and fuel consumption. In particular, we will discuss in detail a common control strategy used in cities, the “green wave” [14], in which a green signal is made to propagate with velocity v_{wave} (the applicability to other synchronization strategies will be discussed below). This control method tends to produce clusters of vehicles, and due to this high correlation, a precise knowledge of the leading car can provide us with information about the cluster itself.

Therefore, as long as the leading car represents the behavior of the cluster to which it belongs, we can describe with a single car model some common states in traffic behaviors involving clusters of vehicles [15]. Because of this, we will limit ourselves in this paper to study a single car moving through a sequence of traffic lights [1]. Even though many models have been proposed to describe the dynamics of cars in cities ([2, 4, 6, 16] among others), our model is simple enough to handle analytically, and nevertheless yields highly nontrivial results which describe, at least qualitatively, behavior present in some practical situations, as discussed in this paper and in [1]. Some approaches have tried to deal with the complexity of traffic in cities, sometimes with various phenomenological components that are capable of reproducing particular situations (see previous references), but these approaches usually do not provide an intuitive understanding of the contributions of each effect. It is for these reasons that we are, using our model as a starting point, developing a first principles approach, where detailed features such as finite accelerating and braking capabilities, or several decision levels, are included; i.e., we are searching for the underlying robust characteristics of traffic in cities. Indeed, we will show below that finite accelerating and braking capabilities may be a relevant source of complexity in city traffic for reasonable city parameters. Furthermore, within this framework, additional effects such as the decision criteria at intersections or different car interactions can then be included in a consistent and systematic manner.

In the model considered in Toledo et al. [1], the dynamics of successive accelerations, brakings, and travels at cruising speed between traffic lights give rise to a map for the evolution of the velocity and travel time at each traffic light. In this paper we also consider the evolution of fuel consumption, another important variable for drivers. We analyze initially the asymptotic behavior of two strategies for the synchronization of traffic lights, namely (a) all traffic lights switching with the same phase, and (b) a green wave with a propagating green signal. It is shown that in this model, the traffic variables such as travel time, velocity and fuel consumption follow critical scaling laws near a resonance, suggesting the existence of a universal behavior of the system in the vicinity of the resonant condition. It is also shown that variations in fuel consumption for a given set of trajectories can be very different from variations in travel time, thus suggesting that it may be very difficult to design traffic light synchronization strategies which optimize both fuel consumption and travel time.

All these results are valid for long travel times, when the system has been able to reach the attractor derived for the asymptotic solution of the map, as it may occur in large cities. However, in situations where trips are not long in general, it makes sense to study the transient dynamics of the system, which we also analyze in the paper. For instance, a third control strategy is studied, which is achieved by changing the phase of the traffic lights at a certain point in the trajectory. This resonance is not global as the green wave, but transient, having only an impact during a few traffic lights. These results may be highly dependent on the detailed history of the system, but they may be relevant in city traffic for the reasons stated above.

The paper is organized as follows. In Sec. II the model is presented. In Sec. III fuel consumption is considered. Then two models of traffic light synchronization are analyzed: all lights in phase (Sec. IV) and the green wave (Sec. V). Scaling laws for the travel time, velocity and fuel consumption are explicitly derived. In Sec. VI transient behavior and transient resonances are studied. Finally, in Sec. VII results are summarized and discussed.

II. THE MODEL

A car in this model can be in one of four states: (a) at rest at the position of a traffic light, (b) with constant acceleration a_+ until its velocity reaches the cruising speed v_{\max} , (c) with constant speed v_{\max} , or (d) with negative acceleration $-a_-$ until it stops or accelerates

again. The dynamics may then be written as

$$\frac{dv}{dt} = \begin{cases} a_+ \theta(v_{\max} - v) , & \text{accelerate,} \\ -a_- \theta(v) , & \text{brake,} \end{cases} \quad (1)$$

where θ is the Heaviside step function. We notice that v_{\max} is the cruising speed of the cars. If the distance between successive traffic lights is a constant L , we can define the cruising time $T_c = L/v_{\max}$. T_c is also the minimum travel time between traffic lights.

The n^{th} light is green if $\sin(\omega_n t + \phi_n) \geq 0$ and red otherwise, where ω_n is the frequency of the traffic light, and ϕ_n is its phase shift. At a distance $x_d = v_{\max}^2/2a_-$ from the next traffic light the driver must make a decision, to step on the brakes or not, depending on the sign of $\sin(\omega_n t + \phi_n)$. If $\sin(\omega_n t + \phi_n) \geq 0$ the driver will continue and pass the signal with v_{\max} . If $\sin(\omega_n t + \phi_n) < 0$ the driver will decelerate until it stops, unless the light changes to green again while braking. In the last situation the car will accelerate again with a_+ . Of course, in principle, a real driver could make the decision before x_d , but we are assuming that the driver moves the decision point as close as possible to the signal, as close as permitted by his/her breaking capacity.

The dynamics generates a nonlinear function that maps time t_n and velocity v_n from light to light, as described in detail in Toledo et al. [1].

III. FUEL CONSUMPTION

Even though travel time and velocity are good characterizations of the efficiency of a road system, fuel consumption is also of interest to drivers. In general, fuel efficiency will improve if the number of times the car stops is reduced, but it depends on the specific sequence of brakings and accelerations, and thus on the initial conditions. However, general conclusions can be obtained by studying the evolution of the attractor solution.

To account for fuel consumption, we need to study the main sources of dissipation in the car's motion. Fuel consumption is proportional to the mechanical energy produced by the engine, given by $\int_{t_0}^{t_f} Fv dt$, where t_0 and t_f are the initial and final times for the complete journey, and F is the forward force or thrust. Besides the engine thrust, we have the rolling friction F_r which opposes the motion, and F_d , where we include other resisting forces such

as aerodynamic drag. Therefore, if m is the car mass, the following equation holds:

$$F = ma_+ + F_r + F_d . \quad (2)$$

An analogous equation for the braking state is not necessary, as we assume that the forward force provided by the engine is zero while braking. Let us consider each term in Eq. (2) separately. The car acceleration is a_+ , as given by Eq. (1), and the total injection of energy due to the acceleration from rest to v_{\max} is $mv_{\max}^2/2$. Each time the car stops this energy is wasted, so this term represents the effect of the driver's behavior on fuel consumption. The rolling friction is estimated as $F_r = \mu mg$, where mg is the weight of the car and μ is the coefficient of rolling friction [17]. Rolling dissipation is thus given by $\int F_r v dt \sim F_r L$, which is a function of the distance between traffic lights. Both sources of energy losses can be compared through the dimensionless number $f_r \equiv 2F_r L/mv_{\max}^2 \sim 2\mu g L/v_{\max}^2$ which is $f_r \sim 0.2$ for a car traveling at 50 km/h between lights 200 m apart and a rolling coefficient of $\mu = 0.01$ [18].

Finally, the force F_d is a function of the car velocity. Most of the fuel consumption in a non-stop journey is due to the rolling and drag forces, since accelerations are minimal. However, if the car passes through a sequence of traffic lights, it moves at lower speeds, and then drag is less important than rolling friction. Hence, we neglect drag dissipation in our analysis. We also neglect other dissipative sources such as the energy needed to keep the motor running (in particular, the energy wasted while standing at the traffic light) and the energy lost due to internal frictions in the car mechanisms [19].

Thus, under city traffic conditions, total fuel consumption can be estimated as

$$C = \int_{t_0}^{t_f} Fv dt = ma_+ L_+ + F_r (L_+ + L_0) , \quad (3)$$

where L_+ is the portion of the traveling length in which the driver was accelerating and L_0 is the distance traveled at constant speed.

IV. RESONANT BEHAVIOR FOR $\phi_n = 0$

In Ref. [1], a specific strategy of traffic light synchronization was considered, namely, all lights have equal phase. This synchronization makes sense only if $L_n = L$. Later on we will relax this restriction when we apply a green wave. If the period of the signals, $2\pi/\omega$, is equal

to the cruising time, T_c , after a short transient (passing a few traffic lights), the car will arrive at each successive decision point when the light's phase is the same. It is important to note that such resonance between the car motion and traffic signals corresponds to a very narrow region of parameters (see the period-1 orbit in Fig. 1). Thus, the interesting regime for controlling traffic situations corresponds to a narrow region around the condition $2\pi/\omega = T_c$. Introducing the dimensionless quantity $\bar{\Omega} = \omega T_c/2\pi$, resonance occurs at $\bar{\Omega} = 1$.

Figure 1 gives the bifurcation diagram of a car starting from rest at the first traffic light. For a given frequency of the traffic lights, characterized by $\bar{\Omega}$, the normalized speed v_n/v_{\max} and time travel between traffic lights $(t_{n+1} - t_n)/T_c$ at the n^{th} light is plotted. A transient of 500 time steps has been removed. This is too large a number of traffic lights to be relevant in real traffic situations, but it is necessary to reach the attractor for all the initial conditions plotted (specially in the region very close to the period-doubling bifurcation, where convergence is particularly slow). However, we should point out that most of the initial conditions converge to the attractor in as few as 5–20 traffic lights.

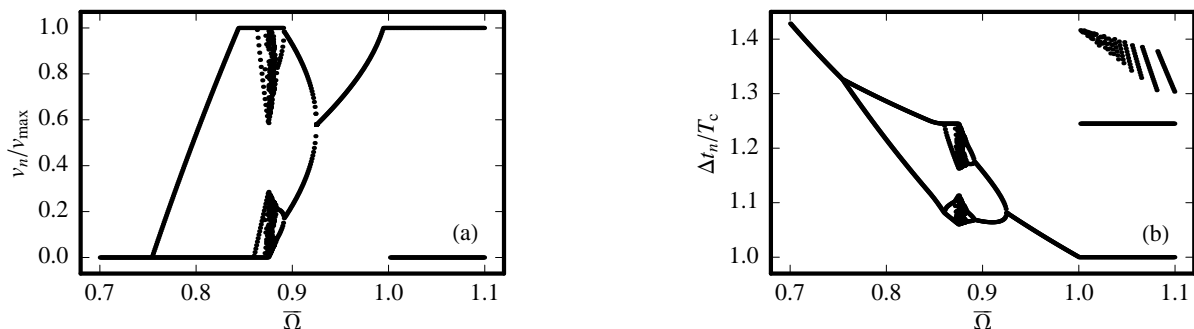

FIG. 1: Bifurcation diagram for the normalized (a) speed at the traffic lights and (b) time travel between traffic lights, versus normalized frequency $\bar{\Omega}$, for $a_+ = 2 \text{ m/s}^2$, $a_- = 6 \text{ m/s}^2$, $v_{\max} = 14 \text{ m/s}$, and $L = 200 \text{ m}$. A transient of 500 time steps has been removed.

It is important to notice that even in this model there is already an interesting nontrivial behavior in the range $0.75 < \bar{\Omega} < 1$ as displayed in Fig. 1, where a necessary condition for complexity emerges even from the dynamics of a single car. It includes a period doubling bifurcation transition to chaos, where the Lyapunov exponent is estimated in Toledo et al. [2004] for a similar situation. It is interesting to note that this chaotic behavior is produced by the finite accelerating and braking capabilities of the cars, and is thus independent of the interactions between cars. This is one of the reasons for proposing our model as

a starting point for a first principles approach to traffic in cities.

Intuitively, and from Fig. 1, at $\bar{\Omega} = 1$ the car motion is in resonance with the traffic lights and the traveling time between two given traffic signals is minimized. For $\bar{\Omega} > 1$ (increasing ω), there are a number of resonances, separated by $\Delta\omega = 2\pi/T_c$. Figure 2 displays the average normalized speed $\langle v \rangle / v_{\max}$ (total distance traveled divided by total time elapsed) as a function of frequency. Successive resonant points are found at $\bar{\Omega} = \ell$, where ℓ is a positive integer. We will see below that these resonances display critical behavior. On the other hand for $\bar{\Omega} < 1$ there are situations in which the car covers a distance qL , with q a positive integer, with cruising speed for half the period of the traffic lights, and then is stopped for the other half of the period. In these cases $\bar{\Omega} = 1/q$ and the average normalized speed is $\langle v \rangle / v_{\max} = 1/2$ as shown in Fig. 2. Since for a reasonable city $L \approx 200$ m and $v_{\max} \approx 50$ km/h, the traffic light period of the first resonance $P = 2\pi/\omega \approx 14$ s is a little unreasonable, an attempt to control the system using this parameter alone seems impractical, however, exploring this dynamics could allow us to derive more practical control schemes.

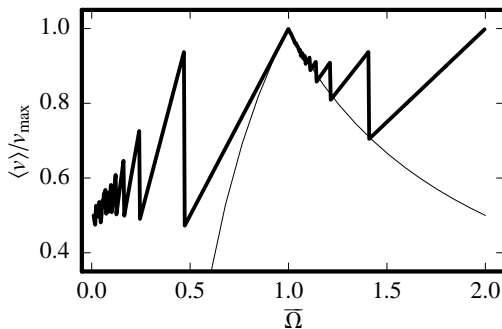

FIG. 2: Resonant tongues showing the average speed (total distance traveled divided by total time elapsed) as a function of the forcing frequency $\bar{\Omega}$. The thin line corresponds to the scaling relation Eq. (22). A transient of 500 time steps has been removed.

In the vicinity of the resonance $\bar{\Omega} \approx 1$, two different dynamics arise depending on the sign of $\bar{\Omega} - 1$. For simplicity, let us consider a car starting at the first traffic light when it changes from red to green, *i.e.*, when the green window begins. If $\bar{\Omega} < 1$, the car will be delayed with respect to the traffic lights, and will reach the second one when it is red, so it will be forced to brake. However, if the delay is small, the traffic light will turn green before the car gets to a full stop, so the car will accelerate again (see Fig. 3), reaching the next traffic light with non-zero velocity. This causes the period-1 orbit below the resonance

$\bar{\Omega} = 1$ of Fig. 1.

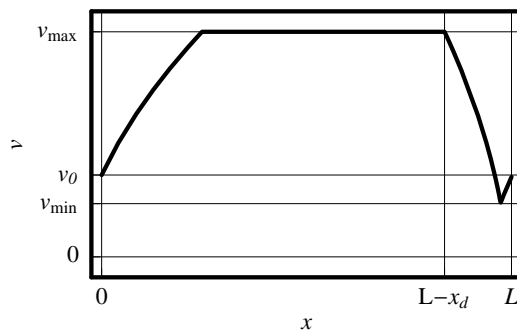

FIG. 3: Speed versus distance for the period-1 attractor below resonance ($\bar{\Omega} < 1$). The car starts at the first traffic light with velocity v_0 , accelerates until reaching velocity v_{\max} , and arrives at the decision point $L - x_d$ when the next traffic light is red, so it brakes. When the velocity is a certain minimum value v_{\min} , the sign turns green, and the car accelerates again, passing the traffic light with the initial speed v_0 .

The situation for $\bar{\Omega} > 1$ is very different. The car reaches the second light a time δt after it has turned green, and this delay increases with each traffic light until it is eventually forced to stop. Thus, for $\bar{\Omega} > 1$, the car moves at maximum speed almost always, except for a stop every p traffic lights, leading to the attractor seen above the resonance in Fig. 1.

To estimate p , we note that the driver arrives at the next signal a small time $\delta t = T_c - 2\pi/\omega > 0$ after the signal turns green, then with a delay $2\delta t$ at the third light, and so on. The journey will continue until the green window is exhausted. The total number of signals, p , that the driver will cross without stopping is given by $p\delta t \approx \pi/\omega$, which leads to

$$p \approx \frac{1}{2} \frac{1}{\bar{\Omega} - 1}. \quad (4)$$

Equation (4) is very interesting, because it also suggests that there is a critical behavior of traffic variables around resonance. However, resonance itself is not a robust feature for $\phi_n = 0$, as it is not independent of the geometry of the road, which is important, because in real situations the distance between traffic lights is not constant, being impossible to maintain resonance traveling at constant speed.

Fortunately, the opposite is true for another kind of traffic light synchronization strategy, the “green wave”, which we now consider.

V. GREEN WAVE

A common strategy for traffic light synchronization is the “green wave”, where a green color signal is moved with a speed v_{wave} , so that the color at the n^{th} traffic light, located at a position x_n along the road, is given by $\sin \omega(t - x_n/v_{\text{wave}})$, where ω is the frequency of the traffic light. This implies that $\phi_n = -\sum_{m=1}^n L_m \omega / v_{\text{wave}}$. The case $\phi_n = 0$ analyzed in Sec. IV is equivalent to the green wave case with $v_{\text{wave}} \rightarrow \infty$.

In Fig. 4 we plot the bifurcation diagram with $\alpha = v_{\text{max}}/v_{\text{wave}}$ of a car starting from rest for a road with constant distance between traffic signals $L_n = L = 200$ m, constant frequency $\omega = 2\pi/60$ s $^{-1}$, accelerations $a_+ = 2$ m/s 2 and $a_- = 6$ m/s 2 , and $v_{\text{wave}} = 14$ m/s. These parameters are reasonable for an actual road, corresponding to a change of lights every 30 s, and a green wave synchronized with cars moving at 50 km/h. The car will follow a complex path unless the velocity of the car coincides with the wave velocity, *i.e.*, a resonance. Under this condition, the driver will never be stopped. However, resonance is rather fragile, as observed in Fig. 4, hence the dynamics must be observed near the resonant condition $\alpha \sim 1$.

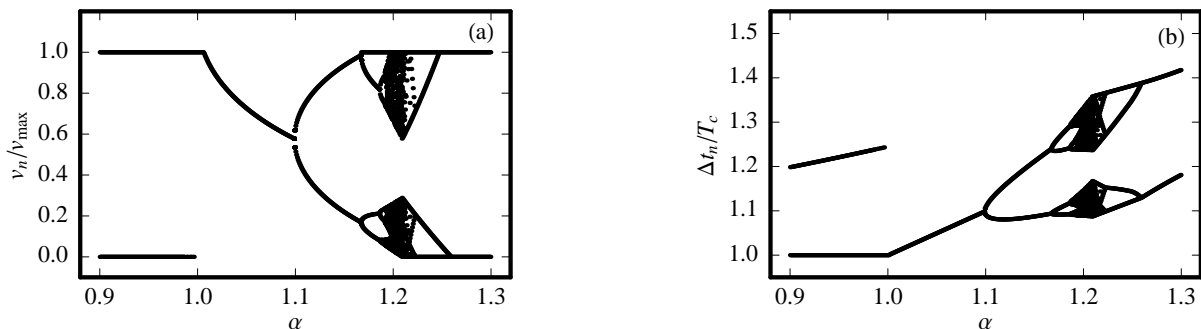

FIG. 4: Bifurcation diagram for (a) normalized speed and (b) normalized time travel between traffic lights, versus α , for $a_+ = 2$ m/s 2 , $a_- = 6$ m/s 2 , $v_{\text{wave}} = 14$ m/s, $\omega = 2\pi/60$ s $^{-1}$, $L = 200$ m. The transient has been removed.

The bifurcation diagram in Fig. 4 is very similar to Fig. 1, but reflected horizontally. Thus, it is above resonance, $\alpha > 1$, that a period-1 solution exists, where the car follows a trajectory like Fig. 3, and below resonance the car crosses a certain number p of lights before being stopped. An approximate expression for p can be obtained for the green wave, using similar arguments to those used to derive Eq. (4).

Let us consider the number of traffic lights the car can pass without braking. In the green wave case, close to resonance, we consider a small perturbation $\delta v = v_{\text{wave}} - v_{\text{max}} > 0$.

In the optimal case, the driver starts at one extreme of the green semi-period just when the signal changes from green to red, so that at the next signal the driver arrives a time $\delta t = L/v_{\max} - L/v_{\text{wave}}$ before the signal turns red. The journey will continue until the green window is exhausted. The total number of signals, p , that the driver will cross without stopping is given by $p \delta t = \pi/\omega$, or

$$p \approx \frac{\lambda/L}{2} \frac{\alpha}{1-\alpha}, \quad (5)$$

where $\lambda = v_{\text{wave}} \cdot 2\pi/\omega$. Criticality is, once more, explicit. However, unlike the case $\phi_n = 0$, resonance for the green wave holds even if the distance between traffic lights is not constant, in which case $\phi_n = -\sum_{m=1}^n L_m \omega / v_{\text{wave}}$.

An interesting example of this independence of geometry for the behavior near resonance is shown in Fig. 5(a) for the average speed after traveling a large number of traffic lights as a function of $\alpha = v_{\max}/v_{\text{wave}}$. Three cases are compared: (i) a street where distance between traffic lights $L_n = L = 200$ m is constant; (ii) a street with a random distribution of distances $L_n = L + \Delta L_n$, where $\Delta L_n/L$ is a uniform random number in the interval $[-0.5, 0.5]$; and (iii) a real street, namely, the longest city street in Chile (the Avenida del Libertador Bernardo O'Higgins, also known as Alameda Avenue; its precise geometry can be obtained from the Chilean Military Geographic Institute at <http://www.igm.cl/>). All curves are identical at resonance. The same is true for the average time between traffic lights. This suggests that behavior near resonance for the green wave, at $\alpha = 1$, is indeed universal, regardless of the detailed geometry of the road. Moreover, it will be shown that near resonance, traffic variables behave according to scaling laws. Thus, Fig. 5 shows the universality of this critical behavior. . The figure also shows how the efficiency of the strategy degrades as the effective speed of the cars gets away from v_{wave} .

Based on Eq. (5), it is now easy to obtain scaling laws for the traffic variables (time, velocity, fuel consumption). At $\alpha = 1$, the system is at resonance, so that the average travel time $\langle t \rangle$ is equal to the time of “free” travel, when no red lights are found, $T_{\text{free}} \equiv nL/v_{\max}$, where n is the number of passed traffic lights. Average velocity is equal to the corresponding maximum or free velocity $\langle v \rangle = V_{\text{free}} \equiv v_{\max}$. Below resonance these relations change because, if $\alpha < 1$, the car is forced to stop at some point. Since π/ω is the time the red light window lasts, the car is at rest a time $\approx k\pi/\omega$ with k as the number of times the driver

brakes. Then the average travel time is

$$\langle t \rangle = T_{\text{free}} + \frac{k\pi}{\omega}. \quad (6)$$

The average velocity in the same run is

$$\langle v \rangle \sim \frac{nL}{\langle t \rangle}. \quad (7)$$

Fuel consumption at resonance, on the other hand, is $\langle C \rangle = C_{\text{free}} \equiv nF_r L$. Below resonance fuel consumption can be estimated by observing that the car stops k times when it covers a distance nL at cruising speed, hence $\langle C \rangle \sim F_r nL + kmV_{\text{free}}^2/2$, which is the total work done by F_r plus the energy wasted in each stop, thus

$$\langle C \rangle \sim C_{\text{free}} \left(1 + \frac{mkV_{\text{free}}^2/2}{nF_r L} \right). \quad (8)$$

Equations (6)–(8) can be written as

$$\begin{aligned} \frac{\langle t \rangle - T_{\text{free}}}{T_{\text{free}}} &\sim \frac{\lambda}{2L} \frac{k}{n} \alpha, \\ \frac{\langle v \rangle - V_{\text{free}}}{V_{\text{free}}} &\sim -\frac{\lambda}{2L} \frac{k}{n} \alpha, \\ \frac{\langle C \rangle - C_{\text{free}}}{C_{\text{free}}} &\sim 1 + \frac{1}{f_r} \frac{k}{n}. \end{aligned}$$

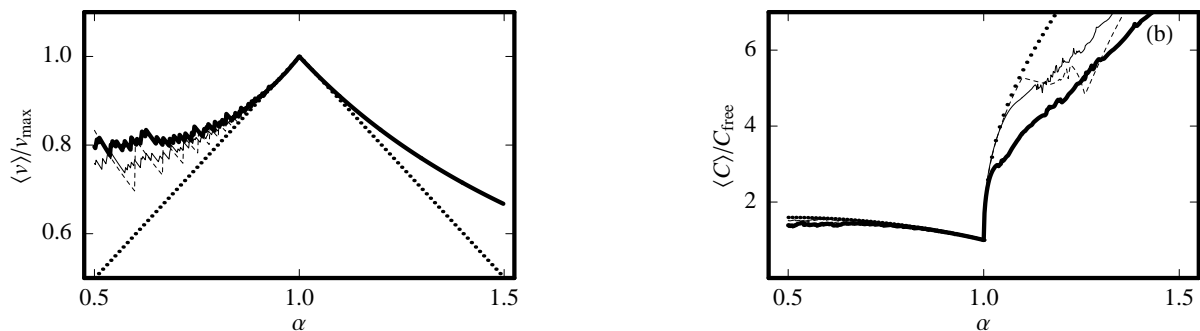

FIG. 5: (a) Resonant tongue showing the average speed (total distance traveled after crossing n signals, divided by time elapsed) as a function of the parameter α . The thin line corresponds to random street length, the thick line corresponds to the Alameda Avenue, the dashed line corresponds to constant street length, and the dotted line corresponds to the scaling laws derived in the text. (b) The corresponding average fuel consumption, normalized to the free consumption $C_{\text{free}} = nF_r L$.

Since after p traffic signals there is one stop, we can estimate $k/n \sim 1/p$. Then, using (5), yields the following scaling laws:

$$\frac{\langle t \rangle}{T_{\text{free}}} \sim 1 + (1 - \alpha) , \quad (9)$$

$$\frac{\langle v \rangle}{V_{\text{free}}} \sim 1 - (1 - \alpha) , \quad (10)$$

$$\frac{\langle C \rangle}{C_{\text{free}}} \sim 1 + \frac{2L/\lambda (1 - \alpha)}{f_r \alpha} . \quad (11)$$

Above resonance ($\alpha > 1$), the period-1 solution is possible if the average time to move between two traffic lights is

$$\langle t \rangle = \frac{L}{v_{\text{wave}}} = T_{\text{free}} \alpha \approx T_{\text{free}} [1 + (\alpha - 1) + \mathcal{O}(\alpha - 1)^2] , \quad (12)$$

and the average velocity is

$$\langle v \rangle = v_{\text{wave}} = \frac{v_{\text{max}}}{\alpha} \approx v_{\text{max}} [1 - (\alpha - 1) + \mathcal{O}(\alpha - 1)^2] . \quad (13)$$

Equations for $\langle t \rangle$, (9) and (12), and for $\langle v \rangle$, (10) and (13), can be combined as

$$\frac{\langle t \rangle}{T_{\text{free}}} = 1 + |1 - \alpha| , \quad (14)$$

$$\frac{\langle v \rangle}{V_{\text{free}}} = 1 - |1 - \alpha| , \quad (15)$$

being symmetrical around resonance.

Symmetric expressions like these cannot be obtained for fuel consumption. In order to estimate fuel consumption above resonance, let us first notice that the trajectory is analogous to Fig. 3. The distance in which rolling friction acts against the engine is

$$x_r = L - \frac{v_{\text{max}}^2 - v_{\text{min}}^2}{2a_-} , \quad (16)$$

and the energy lost when breaking is

$$W_a = \frac{m}{2} (v_{\text{max}}^2 - v_{\text{min}}^2) . \quad (17)$$

Thus, total work between two traffic lights is

$$W = F_r x_r + \frac{m}{2} (v_{\text{max}}^2 - v_{\text{min}}^2) = F_r L + \frac{1}{2} (v_{\text{max}}^2 - v_{\text{min}}^2) \left(m - \frac{F_r}{a_-} \right) . \quad (18)$$

Note that this is equivalent to Eq. (3). In order to obtain v_{\min} , we solve the following set of equations:

$$v_0 = v_{\min} \sqrt{1 + \frac{a_+}{a_-}} , \quad (19)$$

$$T = \left(\frac{v_{\max}}{2} - v_{\min} \right) \left(\frac{1}{a_+} + \frac{1}{a_-} \right) + \frac{v_0^2}{2v_{\max}a_+} + \frac{L}{v_{\max}} . \quad (20)$$

These equations follow from Fig. 3. Equation (20) simply states that the time to travel from one light to the next one is equal to $T = L/v_{\text{wave}}$. Thus,

$$\langle C \rangle \sim C_{\text{free}} \left(1 + \frac{2}{f_r} \left[1 - \frac{F_r}{ma_-} \right] \sqrt{\frac{2a_+a_-}{a_+ + a_-} \frac{L}{v_{\text{wave}}^2} \frac{(\alpha - 1)^{\frac{1}{2}}}{\alpha}} \right) + \mathcal{O}(\alpha - 1) . \quad (21)$$

Fuel consumption behavior is not symmetrical near resonance. This asymmetry is related to the fact that below resonance the car fully stops only once every p signals, whereas above resonance the car never stops, but brakes at every signal. Since C depends strongly on the detailed pattern of acceleration in the trajectory, scalings are different at each side of the resonance. In Fig. 5(b) numerical results, obtained by iterating the map, are plotted, showing good agreement with the approximated expressions Eqs. (11) and (21) (dotted lines). Let us note that f_r is a function of α if we assume that v_{wave} is constant and we vary v_{\max} . For $\alpha > 1$ the scaling law we derived above breaks at the period doubling bifurcation, *i.e.*, $\alpha \approx 1.1$ as seen in Fig. 5(b). The strong asymmetry in this figure also suggests that on average, fuel consumption is higher for “impatient” drivers traveling with velocity above the green wave velocity.

The universality of Eq. (15) is also clearly suggested in Fig. 5(a) for the averaged velocity. This is interesting, as the scaling laws have been obtained for equidistant traffic lights, but also hold for varying street length.

Although this critical behavior has been derived for a single car model, we expect it to have an effect when multiple cars (not too many, otherwise they will form a jam) are in the road as well. Indeed, for a single car, it corresponds to traveling a large number of traffic lights without stopping. Since it would keep its maximum velocity during most of the travel, it would not interact with other cars also in the same situation. Then, the critical behavior, in general, would occur when a bundle of cars passes p lights before being stopped, with $p \gg 1$. This is analogous to a system near a phase transition, when the correlation length goes to infinity. We have obtained analytical results for the critical behavior in our simple model, which could then be compared with more complex simulations and measurements.

It is interesting to notice that the scaling relations for velocity and time traveled derived for the green wave strategy can be mapped to the equivalent scaling laws for the $\phi_n = 0$ strategy by rewriting $\alpha \rightarrow 1/\bar{\Omega}$. The actual derivation follows along similar arguments as the ones used for the green wave strategy. For instance the velocity scaling is

$$\frac{\langle v \rangle}{V_{\max}} = 1 - \frac{|1 - \bar{\Omega}|}{\bar{\Omega}}, \quad (22)$$

displayed as the thin line in Fig. 2. In the case of fuel consumption for $\alpha > 1$ (and $\bar{\Omega} < 1$), this mapping is even more evident, since we need to carry the same analysis as above, but with $T = L/v_{\text{wave}} \rightarrow 2\pi/\omega$, *i.e.*, $\alpha \rightarrow 1/\bar{\Omega}$.

VI. TRANSIENT BEHAVIOR

The results stated in the previous sections regarding resonance and critical behavior for the green wave are valid in the asymptotic regime of the car dynamics. They are valid regardless of the detailed geometry of the system (characterized by the distance L_n between traffic lights). However, trips in cities are typically short, and transient dynamics cannot be neglected in general. In the following sections we intend to describe some features of the transient behavior which may be of interest for city traffic.

Let us consider the green wave strategy. Figure 6 is analogous to Fig. 4(a), but the transient is also shown. In Fig. 6(b) the car starts later. The change in start time is relevant only in the transient part, and of course, both trajectories converge to the same attractor of Fig. 4(a).

Figure 6 shows that, depending on the initial conditions, the evolution can be quite complex, which as mentioned above, may be relevant for city traffic. In particular, strategies for optimizing fuel consumption turn out not to be very obvious even in our simple model. For instance, let us consider the condition $\alpha = 1.3$. The asymptotic solution is a period two orbit with $v_n = 0$ and $v_{n+1} = v_{\max}$ (see Fig. 6). This situation represents a simple case with an interesting asymptotic behavior that may be quite annoying for the drivers. The left panel in Fig. 7 shows v_n/v_{\max} at traffic lights $n = 3$ and $n = 20$ [Figs. 7(a) and (b), respectively] for a range of initial conditions in time and velocity. For the same traffic lights we also compute fuel consumption with Eq. (3). This is plotted in the right panel in Fig. 7. Darker (lighter) color represents lower (higher) fuel consumption. Note that these zones are

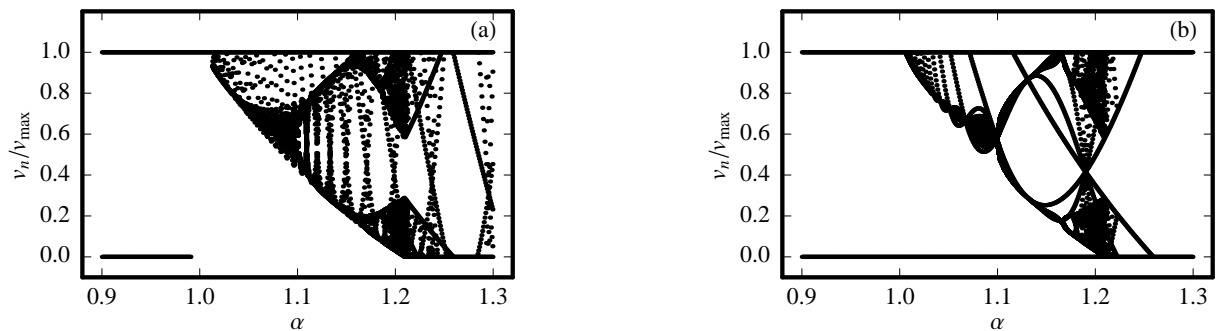

FIG. 6: Bifurcation diagram for the normalized speed v_n/v_{\max} as the control parameter $\alpha = v_{\max}/v_{\text{wave}}$ is varied. Each figure corresponds to a different initial condition: (a) $t_0 = 0, v_0 = 0$, and (b) $t_0 = \pi/\omega, v_0 = 0$. They contain the transient.

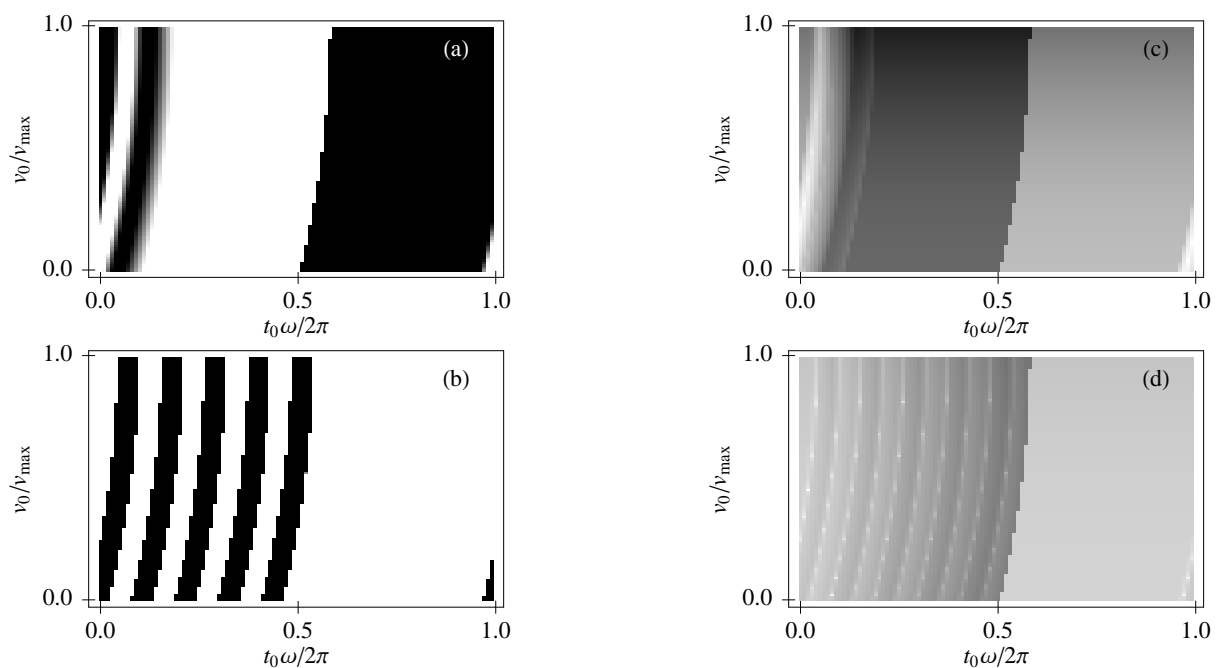

FIG. 7: Transient behavior for $\alpha = 1.3$ according to the initial conditions in the $v_0/v_{\max}-\omega t_0/2\pi$ plane. Lighter tones correspond to higher speeds and higher fuel consumption when crossing the traffic light. In Figs. (a) and (b), we show the distribution of speed for the third and the twentieth traffic light respectively. In the second column, Figs. (c) and (d), we show the associated fuel consumption. Fuel consumption is normalized by the maximum fuel consumption among all trajectories analyzed.

fairly wide and inhomogeneous. Also, there are points associated to high consumption very near to points of low consumption. This result points to the difficulty in designing strategies

to save fuel or time in city traffic, as optimizations in time traveled may conflict with fuel consumption considerations.

An interesting feature is shown in Fig. 8, for the green wave case, with $\alpha = 1.3$. For two trajectories, the difference in travel time after $n = 20$ traffic lights is negligible, whereas they vary by $\sim 20\Delta C_{\text{free}}$ in fuel consumption. These results show that fuel consumption can be a more sensible index to characterize the efficiency of the road system, as compared to travel time, and point out again the difficulty in devising general strategies for traffic control.

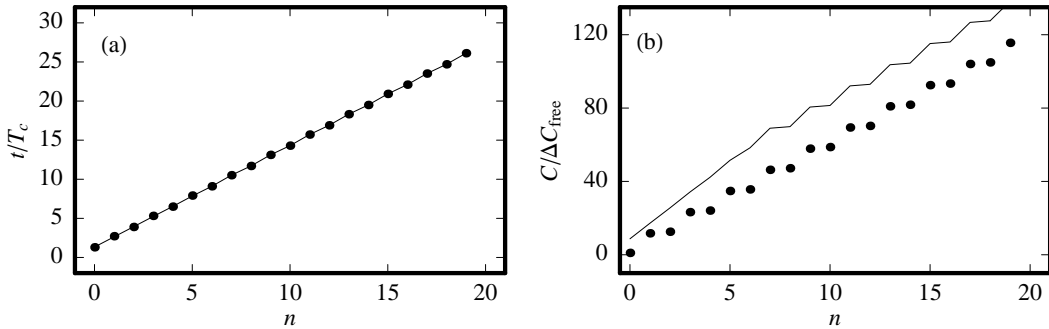

FIG. 8: The comparison of the (a) time traveled (normalized to T_c) and (b) fuel consumption (normalized to $\Delta C_{\text{free}} = F_r L$), for $\alpha = 1.3$, for two particular initial conditions, $v_0 = 18.02$ m/s and $v_0 = 4.55$ m/s, respectively. The rest of the parameters are those for Fig. 4.

Another way to state this is to consider a set of initial conditions distributed uniformly in the v - t plane, and let the trajectories evolve. After $n = 3$ and $n = 20$ traffic lights, the distributions of time and fuel consumption are reconstructed and displayed in Fig. 9 with the same arrangement as in Fig. 7. We note that the distributions are highly asymmetrical and tend to be centered around a certain point that is related to the corresponding asymptotic expression for $\alpha = 1.3$, shown in Fig. 5(a). The width of the distribution for fuel consumption is larger than the width of the distribution for elapsed time, which is consistent with Fig. 8. This shows the high sensitivity of this variable and suggests its relevance in city traffic. On the other hand, let us remember that in this figure we are representing a statistical distribution, at a given time, of a big number of initial conditions randomly chosen over the whole phase space. The variations that we are seeing here characterize the nontrivial transient part of the trajectories. For the period-2 situation we are considering here, there exist a maximum asymptotic spread in time because of those cars that are caught by a red light during the transient part of the trajectory (remember that the average waiting time

at the traffic light is $\sim 2T_c$). Therefore, we can see the convergence of the time distribution to two well defined peaks, whereas for the fuel distribution the two hills shown in Fig. 9(c) will merge into the one observed in Fig. 9(d).

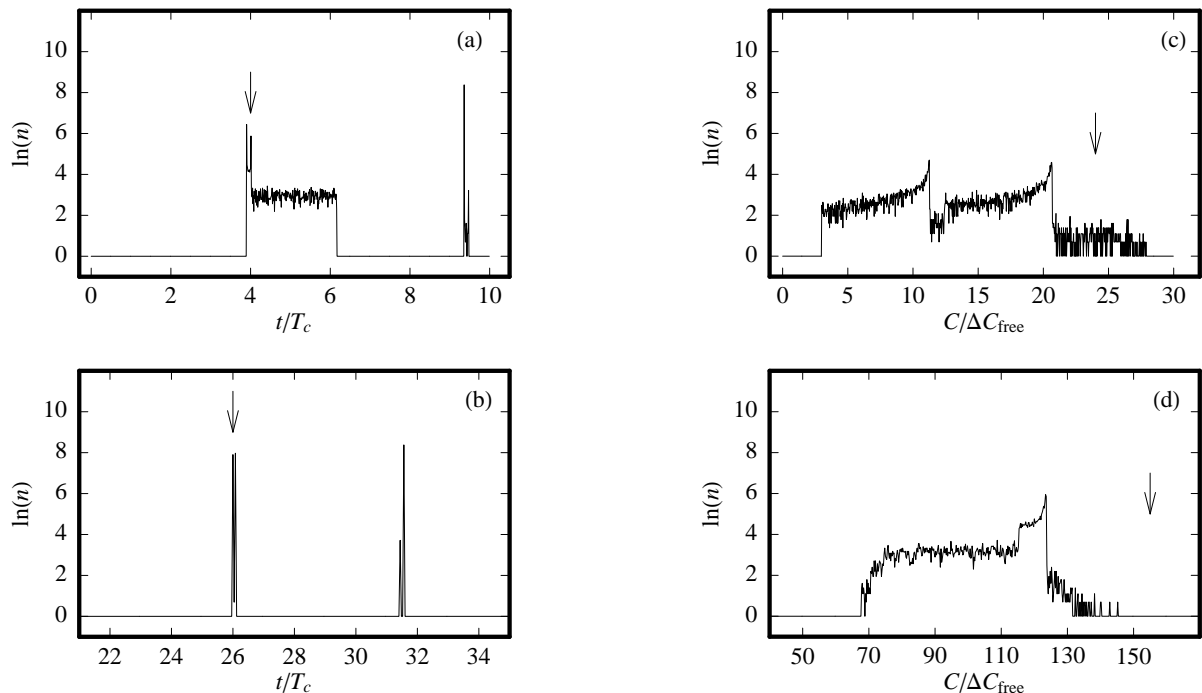

FIG. 9: Transient distributions as measured at different traffic lights for $\alpha = 1.3$, produced by different initial conditions distributed uniformly in the $v_0/v_{\max}-\omega t_0/2\pi$ plane. In Figs. (a) and (b), we show the distributions of time traveled for the third and the twentieth traffic light respectively. The time has been normalized by T_c . In the second column, Figs. (c) and (d), we show the associated distribution of fuel consumption. Fuel consumption has been normalized by $\Delta C_{\text{free}} = F_r L$. The vertical arrows are the predictions by the asymptotic formulation given by Eqs. (15) and (21). As expected from Fig. 5(b), the prediction for fuel consumption is not very good for $\alpha = 1.3$.

If we are interested in short trips, we may devise strategies that can minimize certain variables by inducing certain transients. For instance let us take $\alpha = 1.19$ where we have a period-4 orbit, and $\alpha = 1.2$ where the orbit is chaotic. However, if at the 10th traffic light the phase is changed from 0 to π , a transition to free resonant motion is observed. This motion eventually collapses back to the period-4 or chaotic orbits respectively [see Fig. 10(a)], but only after going through a nice transient of p traffic lights, which is in close agreement with Eq. (4). As displayed in Fig. 10(b), the phase induced green corridor proposed above reduces

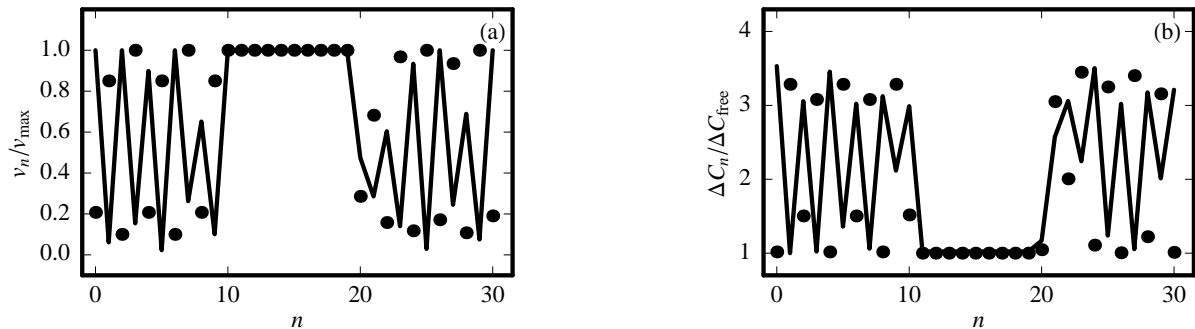

FIG. 10: Orbit collapsing due to the phase change $\phi : 0 \rightarrow \pi$ at the 10th traffic light. In both figures, the period-4 orbit is represented by dots, and the chaotic orbit by a line. (a) Period-4 to free motion and chaos to free motion collapsing. (b) Fuel consumption between lights, ΔC_n , normalized by its minimum value $\Delta C_{\text{free}} = F_r L$.

fuel consumption because rolling friction is the only source of dissipation. This analysis may suggest another control strategy to improve traffic flow by adaptively changing traffic lights phases. It also gives further insight into the origin of complex solutions when the resonance condition is approached. As time progresses, a periodic or chaotic solution suddenly may spot a green corridor that changes completely its observed trajectory.

VII. CONCLUSIONS

In this paper, the dynamics of a single car moving between traffic lights is studied. The model, presented in Toledo et al. [1], is studied for two types of synchronization strategies for the traffic lights: all lights in phase, and the green wave. The resonant state, where the car makes a non-stop journey through the complete sequence of traffic lights, was considered. Near resonance, we observe critical behavior, in the sense that traffic variables such as traveling time, average velocity and fuel consumption are described by scaling laws. We also show that this is a universal behavior, independent of the geometry of the system for the case of the green wave strategy. Scaling laws for average time and velocity are symmetrical near resonance, but farther from resonance this symmetry is broken. The asymmetry is also evident in the scaling for fuel consumption, even near resonance. This is due to the different dynamics at each side of the resonance. One side corresponds to the car that always reaches the signals at maximum speed, except for sporadic stops, whereas at the other side the car

brakes and then accelerates again before fully stopping at every signal.

In this paper we also studied features of the model specifically related to the transient behavior. This is particularly relevant for situations in which travel lengths are short in general, and there may be not enough time to reach the asymptotic attractor, depending on the initial conditions. It was shown that, even though at exact resonance all traffic variables are optimized asymptotically, this may not be true during the transient. Moreover, trajectories where small variations in initial condition lead to small variations in traveling time, for instance, largely differ in fuel consumption. This makes the design of strategies of traffic control more difficult.

Besides the global resonances at $\bar{\Omega} = 1$ and $\alpha = 1$, transient resonances appear in the system, where periodic or chaotic orbits spot a “green corridor”, and temporarily collapse to resonant orbits. This can be achieved by appropriately changing the phase of traffic lights at a given point in the road, and may lead to a different strategy of traffic control.

On the other hand, it is important to note that any strategy based on a green wave is direction dependent, so in a bidirectional road of arbitrary geometry, only one way will experience its goodness (except for the $\phi_n = 0$ case). At least in cities like Santiago, Chile, this is a reasonable situation, because the bulk of cars usually moves in a given direction at a given time.

Although, we have studied the “green wave” synchronization for just one car, the effects described here should be more general as discussed in the introduction. Linking traffic lights is one approach to more intelligent roads, and subtle changes can have big effects. Synchronization of traffic lights with the characteristic car dynamics leads to resonance and critical behavior, and both are novel features that deserve further theoretical and experimental work. Long transients, period doubling, chaos, and criticality are concomitant with the resonant character of city traffic models, and these features are expected to be robust and survive in more realistic situations, where more cars and different geometries are involved. For example, we could conjecture that as we introduce a not too large a number of interacting cars into our road system, the effective v_{\max} should diminish with the number of cars in a mean field approach. Which means that the model described here would apply, except that the scaling laws should now scale with the number of cars. However, car accelerations a_{\pm} could also change when more cars are present, and this will also affect any pre-established synchronization with the traffic lights. Such a study is currently under development and

will be published elsewhere.

Acknowledgments

This project has been financially supported by the postdoctoral fellowship MECESUP-USA-0108, and by FONDECyT under contracts 1030727, 1030957, 3060029, and 1060830.

-
- [1] B. A. Toledo, V. Muñoz, J. Rogan, C. Tenreiro, and J. A. Valdivia, *Phys. Rev. E* **70**, 016107 (2004).
 - [2] T. Nagatani, *Phys. A* **348**, 561 (2005).
 - [3] H. K. Lee, R. Barlovic, M. Schreckenberg, and D. Kim, *Phys. Rev. Lett.* **92**, 238702 (2004).
 - [4] J. Matsukidaira and K. Nishinari, *Phys. Rev. Lett.* **90**, 088701 (2003).
 - [5] N. Mitarai and H. Nakanishi, *Phys. Rev. Lett.* **85**, 1766 (2000).
 - [6] K. Nishinari, M. Treiber, and D. Helbing, *Phys. Rev. E* **68**, 067101 (2003).
 - [7] D. Huang, *Phys. Rev. E* **68**, 046112 (2003).
 - [8] M. Treiber and D. Helbing, *Phys. Rev. E* **68**, 046119 (2003).
 - [9] K. Hasebe, A. Nakayama, and Y. Sugiyama, *Phys. Rev. E* **68**, 026102 (2003).
 - [10] T. Nagatani, *Phys. A* **368**, 560 (2006).
 - [11] H. Mitani, in *Proceedings of The 8th Tohwa University International Symposium on Slow Dynamics in Complex Systems, Fukuoka, Japan, 9–14 November 1998*, edited by M. Tokuyama (AIP Conference Proceeding Series, 1999), vol. 469, pp. 703–704.
 - [12] H. Mitani and H. Mori, in *Control in Transportation Systems 2003*, edited by S. Tsugawa and M. Aoki (Elsevier, 2004), p. 329, Proceedings of the 10th IFAC Symposium, Tokyo, Japan, 4–6 August 2003.
 - [13] K. Nagel and M. Paczuski, *Phys. Rev. E* **51**, 2909 (1994).
 - [14] E. Brockfeld, R. Barlovic, A. Schadschneider, and M. Schreckenberg, *Phys. Rev. E* **64**, 056132 (2001).
 - [15] D. Huang and W. Huang, *Phys. Rev. E* **67**, 056124 (2003).
 - [16] M. Bando, K. Hasebe, A. Nakayama, A. Shibata, and Y. Sugiyama, *Phys. Rev. E* **51**, 1035 (1995).

- [17] I. Evans, *British J. Appl. Phys.* **5**, 187 (1954).
- [18] G. Stachowiak and A. W. Batchlor, *Engineering Tribology* (Butterworth-Heinemann, 2001).
- [19] R. H. Essenhigh, *Transportation Research* **8**, 457 (1974).